

LEADSCREW COVERS

- All Steel Box
- Swarf & cutting emulsion resistant
- Standard brackets supplied
- Overall length of bed and width of shafts is required
- Maximum length 2500mm.

Manufactured with a steel casing, the guard uses heavy weight neoprene nylon as its sheet medium, sprung to give a full closure against the leadscrew, therefore offering full protection for the operator.

Additional fixing brackets may be needed

Part No	Description
70006	Leadscrew Roller Cover x Overall Length of Bed

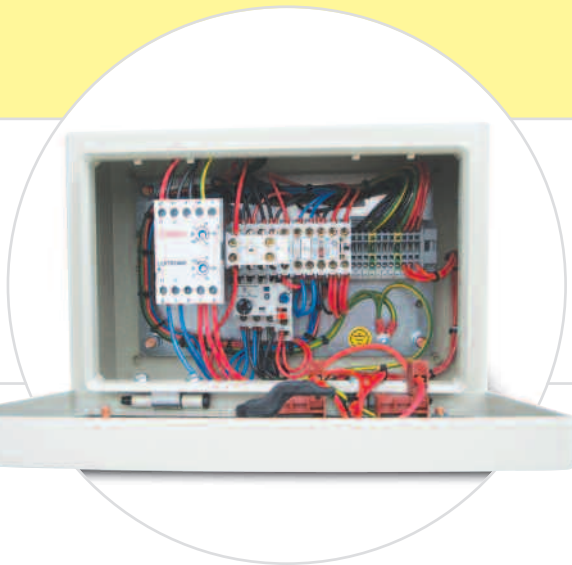
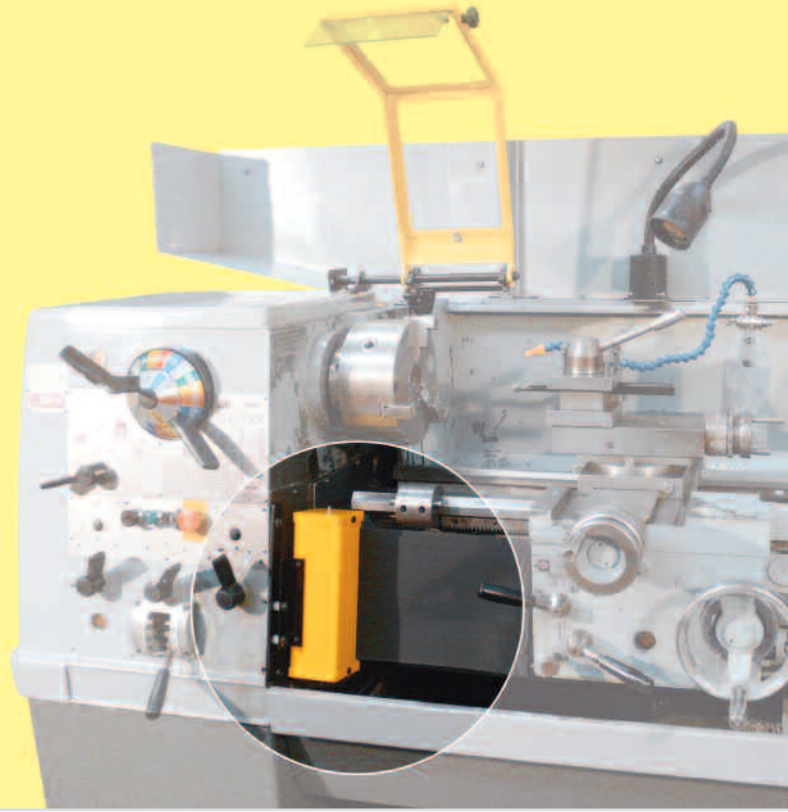

QS10 units are suitable for dual wound, D.O.L. motors.

Supply Voltage:

From 240 volts single phase to 415 volts 3 phase 50 Hz.

Standard Models:

QS2: For motors up to 3 h.p. (2.2kW) D.O.L. 3 phase or up to 0.75 h.p. (0.55kW) single phase.

QS5: For motors up to 7.5 h.p. D.O.L. 3 phase or up to 1 h.p. single phase.

QS10: For motors up to 10 h.p. (7.5kW) D.O.L. 3 phase or up to 2 h.p. (1.5kW) single phase.



EMERGENCY BRAKING SYSTEMS FOR ALL TYPES OF MACHINERY INCLUDING RADIAL DRILLERS

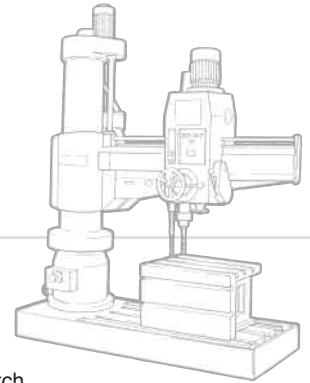

The Quickstop DC injection braking unit provides a rapid or controlled stop every time the tripping device is activated. This could be a trip switch, stop button or any device which opens its contact when operated.

The device works by cutting the A.C. supply to the electric motor and then injecting D.C. into the motor windings. This causes a magnetic field in the stator that causes the rotor in the motor to stop.

Our range comprises of two types - a transformer rectifier type and/or an electronic device style.

For rapid stop that is required for a radial drill - the transformer rectifier type is recommended because it has a quicker response time.

For most other applications - the electronic units are normally suitable.

Part No.	Motor	Description
50001	0 - 3 h.p.	Direct On Line (QS2) 300 x 200 x 150mm
50003	0 - 7.5 h.p.	Direct On Line (QS5) 300 x 200 x 150mm
50002	0 - 10 h.p.	Direct On Line (QS10) 300 x 200 x 150mm
	0 - 10 h.p.	Direct On Line (QS10) TRANSFORMER TYPE 400 x 400 x 200mm

Above 7.5KW (10HP) Star Delta units made to order